

# 3TG10 Power Relays/Miniature Contactors

4-pole, 4 kW

## Overview

### *Version*

The 3TG10 power relays/miniature contactors with 4 main contacts are available with 6.3 mm × 0.8 mm screw terminals or flat connectors. The versions with screw terminals are climate-proof and finger-safe according to EN 61140.

The 3TG10 power relays/miniature contactors are small. The overall width is 36 mm.

## 3TG10 Power Relays/Miniature Contactors

4-pole, 4 kW

## Technical specifications

Type		3TG10	
<b>General data</b>			
<b>Endurance</b>			
• Mechanical	Operating cycles		3 million
• Electrical	Operating cycles		0.1 million
- AC-1 at $I_e$	Operating cycles		0.4 million
- AC-3 at $I_e$			
<b>Rated insulation voltage <math>U_i</math></b> (degree of pollution 3)		V	400
<b>Rated impulse withstand voltage <math>U_{imp}</math></b>		kV	4
<b>Safe isolation</b> between the coil and the contacts acc. to EN 60947-1, Appendix N			
<b>Permissible ambient temperature</b>			
	During operation <sup>1)</sup>	°C	-25 ... + 55
	During storage	°C	-50 ... + 80
<b>Degree of protection</b> acc. to IEC 60947-1 and EN 60529 (VDE 0470 Part 1)			IP00, drive system IP20
<b>Power consumption of the magnetic coils</b> (when coil is cold and $1.0 \times U_s$ )			
	AC operation 45 ... 450 Hz	VA	4.4
	P.f.		0.9 (hum-free)
	DC operation	W	4
<b>Magnetic coil operating range</b>			$0.85 \dots 1.1 \times U_s$
<b>Operating times</b> (Total break time = OFF-delay + Arcing time)			
• ON-delay			
- Closing NO	- DC operation	ms	11 ... 50
	- AC operation	ms	10 ... 50
- Opening NC	- DC operation	ms	21 ... 39
	- AC operation	ms	20 ... 30
• OFF-delay			
- Closing NC	- DC operation	ms	5 ... 45
	- AC operation	ms	5 ... 45
- Opening NO	- DC operation	ms	19 ... 35
	- AC operation	ms	20 ... 30
Arcing time		ms	10 ... 15
<b>Shock resistance</b>			
• Rectangular pulse	AC operation and DC operation	g/ms	5.1/5 and 3.5/10
• Sine pulse	AC operation and DC operation	g/ms	7.9/5 and 5.2/10
<b>Switching frequency <math>z</math></b> in operating cycles/hour rated operation			
	Acc. to AC-1	1/h	1000
	Acc. to AC-2	1/h	500
	Acc. to AC-3	1/h	1000
	No-load switching frequency	1/h	10000
<b>Short-circuit protection</b>			
<b>Fuse links</b> gL/gG operational class LV HRC 3NA, DIAZED 5SB, NEOZED 5SE acc. to IEC 60947-4-1 (VDE 0660 Part 102)			
	• Type of coordination "1"	A	25
	• Type of coordination "2"	A	10
• Miniature circuit breakers	C Characteristic	A	10
<b>AC capacity</b>			
<b>Utilization category AC-1, switching resistive loads</b>			
<b>Rated operational current <math>I_e</math></b> up to 400 V at 55 °C <sup>1)</sup>		A	20 for screw terminals, 16 for flat connector
<b>Rated power <math>U_e</math></b> for AC loads with p.f. = 1, 230/220 V			
• For screw terminals		kW	7.5 (13 at 400 V)
• For flat connector		kW	6 (10 at 400 V)
Minimum conductor cross-section for load with $I_e$		mm <sup>2</sup>	2.5
<b>Utilization category AC-2 and AC-3</b>			
<b>Operational current for AC-3 at 400 V rated value</b>		A	8.4
Rated power for slipring or squirrel-cage motors with 50 Hz and 60 Hz and at 400 V		W	4000
<b>Utilization category AC-5a</b> (permissible nominal impedance: $\geq 0.5 \Omega$ )			
<b>Switching gas discharge lamps</b>			
• Per main current path at 230 V, 50 Hz Rated power/rated operational current per lamp			
• Uncorrected	18 W	0.37 A	43
	36 W	0.43 A	37
	58 W	0.67 A	24
• Lead-lag circuit	18 W	2 x 0.11 A	2 x 81
	36 W	2 x 0.21 A	2 x 42
	58 W	2 x 0.32 A	2 x 28

<sup>1)</sup> If the three main current paths carry a load of 20 A, the following applies if  $I > 10$  A for the fourth conducting path: permissible ambient temperature 40 °C.

# 3TG10 Power Relays/Miniature Contactors

## 4-pole, 4 kW

Type	3TG10				
<b>AC capacity</b>					
<b>Switching gas discharge lamps with correction, solid-state ballast</b>					
Per main current path 230 V, 50 Hz					
Rated power per lamp/capacitance/rated operational current per lamp					
• Shunt compensation	L18 W	4.5 µF	0.11 A	Units	15
	L36 W	4.5 µF	0.21 A	Units	15
	L58 W	7 µF	0.32 A	Units	10
• With solid-state ballast (single lamp)	L18 W	6.8 µF	0.10 A	Units	39
	L36 W	6.8 µF	0.18 A	Units	39
	L58 W	10 µF	0.27 A	Units	26
• With solid-state ballast (two lamps)	L18 W	10 µF	0.18 A	Units	2 x 26
	L36 W	10 µF	0.35 A	Units	2 x 26
	L58 W	22 µF	0.52 A	Units	2 x 12
<b>Utilization category AC-5b, switching incandescent lamps</b>					
Per main current path at 230 V, 50 Hz					
<b>Load rating with DC</b>					
<b>Utilization category DC-1, switching resistive load (<math>L/R \leq 15</math> ms)</b>					
<b>Rated operational currents <math>I_e</math></b>					
• 1 conducting path	up to 24 V	A	16		
	60 V	A	6		
	110 V	A	2		
	220 / 240 V	A	0.8		
	up to 24 V	A	16		
• 2 conducting paths in series	60 V	A	16		
	110 V	A	6		
	220 / 240 V	A	1.6		
	up to 24 V	A	18		
	60 V	A	18		
• 3 conducting paths in series	110 V	A	16		
	220 / 240 V	A	6		
	up to 24 V	A	20		
	60 V	A	20		
	110 V	A	20		
• 4 conducting paths in series	220 / 240 V	A	20		
	<b>Utilization category DC-3 and DC-5, Shunt-wound and series-wound motors (<math>L/R \leq 15</math> ms)</b>				
	<b>Rated operational currents <math>I_e</math></b>				
• 1 conducting path	Up to 24 V	A	10		
	60 V	A	0.5		
	110 V	A	0.15		
	220 / 240 V	A	0		
	up to 24 V	A	16		
• 2 conducting paths in series	60 V	A	5		
	110 V	A	0.35		
	220 / 240 V	A	0		
	up to 24 V	A	16		
	60 V	A	16		
• 3 conducting paths in series	110 V	A	10		
	220 / 240 V	A	1.75		
	up to 24 V	A	18		
	60 V	A	16		
	110 V	A	10		
• 4 conducting paths in series	220 / 240 V	A	2		
	<b>Conductor cross-sections</b>				
	<b>With screw terminals</b>				
• Finely stranded with end sleeve (DIN 46228 Form A/D/C)	mm <sup>2</sup>	M3			
• Solid	mm <sup>2</sup>	2 x (0.75 ... 2.5)			
<b>With flat connector</b>					
• Finely stranded 6.3 mm plug-in sleeve acc. to DIN 46245/46247	mm <sup>2</sup>	0.5 ... 1			
- 6.3 ... 1	mm <sup>2</sup>	1 ... 2.5			
- 6.3 ... 2.5	mm <sup>2</sup>				
<b>CSA and UL rated data (screw terminals)</b>					
<b>Rated insulation voltage</b>	AC	V	600		
<b>Uninterrupted current</b>	Open and enclosed	A	20		
<b>Maximum horsepower ratings</b>					
(CSA and UL approved values)					
Rated power for induction motors with 60 Hz					
at 115 V	hp	0.5/ --			
200 V	hp	1/3			
230 V	hp	1.5/3			
460 V	hp	0/5			
575 V	hp	0/5			
600 V	hp	0/5			

For short-circuit protection with overload relays  
see Protection Equipment: Overload Relays

# Controls – Contactors and Contactor Assemblies

## Project planning aids

### 3RA14 contactor assemblies for wye-delta starting

Sizes S3 – S3 – S2

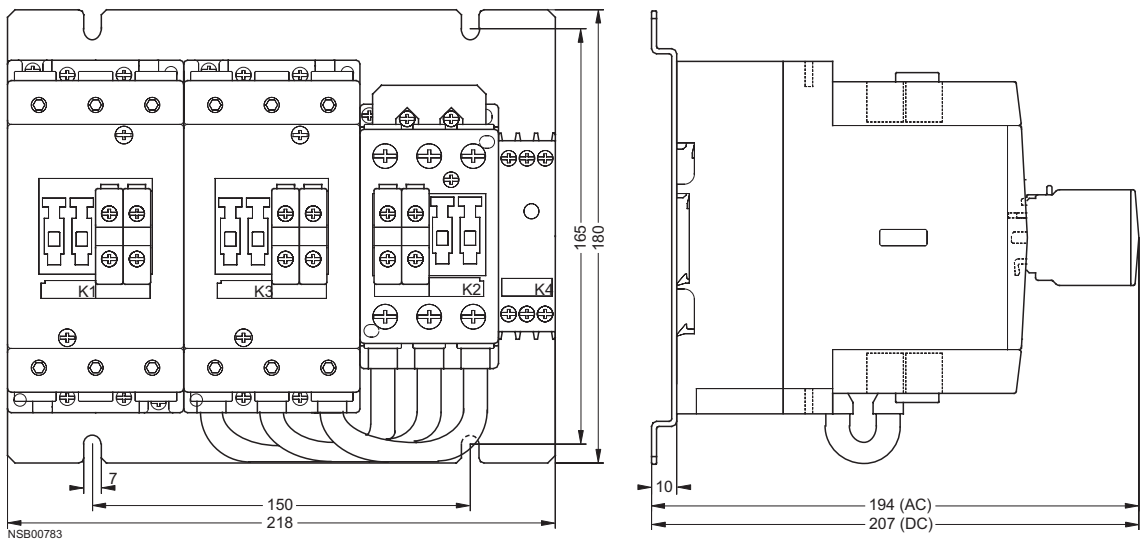

### 3TG10 miniature contactors

3TG10 ..-0.. contactors with screw terminals

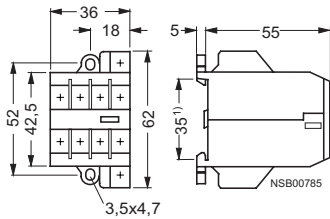

3TG10 ..-1.. contactors with tab connectors

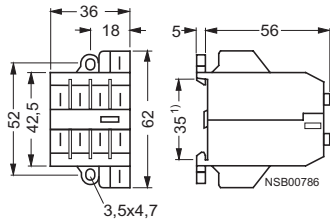

3TG10 contactors with 3UA7 overload relay

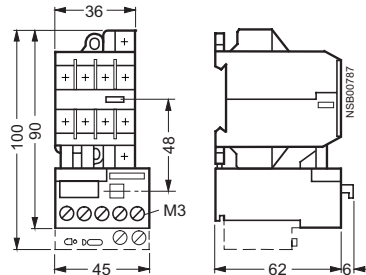

3RT19 16-4BB41 links for paralleling, 4-pole, with connection terminal for 3TG10 contactors

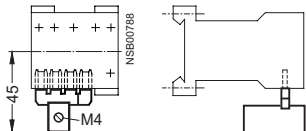

The links for paralleling can be reduced by one pole.

1) Can be snapped onto 35 mm standard mounting rail.

### Internal circuit diagrams for 3TG10 miniature contactors

3TG10 10 contactors

**1 NO**

Ident. No.: 10E

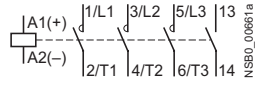

3TG10 01 contactors

**1 NC**

01E

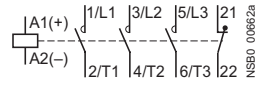

### Internal circuit diagrams for 3TF68 and 3TF69 vacuum contactors, 3-pole

3TF68 44 and 3TF69 44 contactors

**4 NO + 4 NC**

AC operation

Maximum number of auxiliary contacts that can be fitted

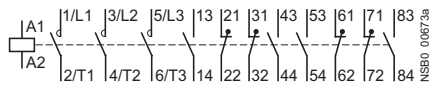

3TF68 33 and 3TF69 33 contactors

**3 NO + 3 NC**

DC operation

Maximum number of auxiliary contacts that can be fitted

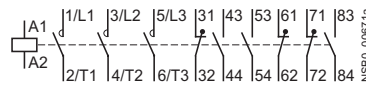

3TY7 681-1G auxiliary switch blocks

for coil reconnection, 3TF68 and 3TF69, DC economy circuit



3TY7 561-1AA00 auxiliary switch blocks

1st auxiliary switch block left or right

mounted on left    mounted on right



3TY7 561-1KA00 auxiliary switch blocks

2nd auxiliary switch block left or right

mounted on left    mounted on right



3TY7 561-1EA00 auxiliary switch blocks

with overlapping contacting

mounted on left    mounted on right



3TY7 561-1 auxiliary switch blocks

Solid-state compatible auxiliary switch block

mounted on left    mounted on right



3TX7 090-0D coupling links for control by PLC

with surge suppression

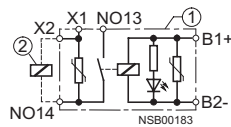

① Coupling link

② Contactor

### Circuit diagrams for 3TF68 and 3TF69 vacuum contactors, 3-pole

**DC economy circuit · Maintained-contact operation**

3TF68 33-.D.4 and 3TF69 33-.D.4 contactors

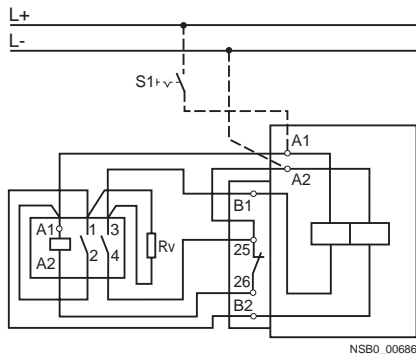

**For AC control supply voltage subject to strong interference**

3TF68 33-.Q.7 and 3TF69 33-.Q.7 contactors

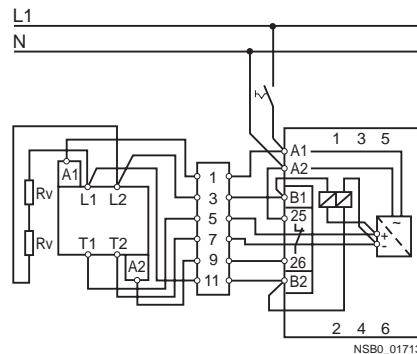

# Controls – Contactors and Contactor Assemblies

## Project planning aids

### Circuit diagrams for 3T contactors with extended operating range 0.7 to 1.25 x U<sub>s</sub>

Circuit with series resistor R<sub>v</sub> (size 2 or larger) without reversing contactor

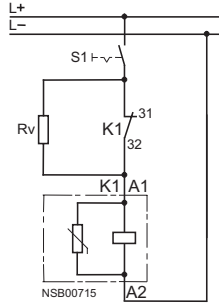

Circuit with series resistor R<sub>v</sub> and reversing contactor K2 (for K1 contactors size 8 or larger)

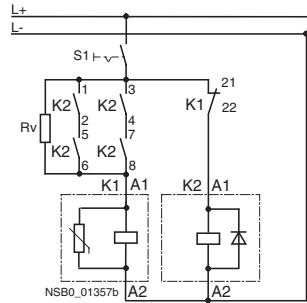

R<sub>v</sub>:  
Two resistors are connected in series for 3TB54, 3TB56 and 3TC56 contactors.

K2:  
For 3TB52 to 3TB56 and 3TC52 to 3TC56:  
3RT13 17-1F.40

### Position of the terminals for 3TG10 miniature contactors

3TG10 10 contactors

**1 NO**

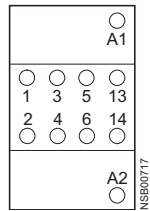

3TG10 01 contactors

**1 NC**

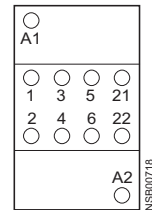

### Position of the terminals for 3TF68 and 3TF69 vacuum contactors, 3-pole

AC operation

3TF68 and 3TF69 contactors

**4 NO + 4 NC**

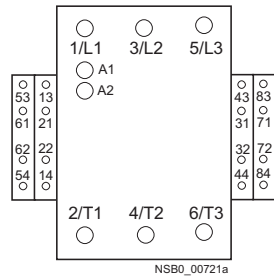

DC operation

3TF68 and 3TF69 contactors

**3 NO + 3 NC**

Maximum number of auxiliary contacts that can be fitted

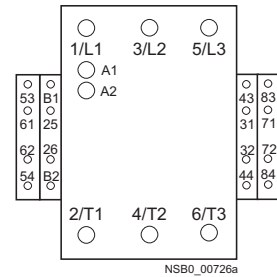

3TY7 561-1 solid-state compatible auxiliary switch blocks for lateral mounting

Left mounted

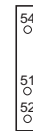

Right mounted

